



INSTRUCTION MANUAL
BATTERY CHARGERS - STARTERS

EXPLANATION OF DANGER

1. GENERAL SAFETY RULES FOR THE USE	4
2. GENERAL DESCRIPTION	4
2.1 TRADITIONAL BATTERY CHARGERS	4
3. BOOST FUNCTIONS	4
4. AMMETER READING.....	4
5. INSTALLATION	4
5.1 ASSEMBLY.....	4
5.2 POSITIONING THE BATTERY CHARGER.....	4
5.3 CONNECTION TO THE MAIN SUPPLY.....	4
6. OPERATION DURING CHARGING.....	4
6.1 BATTERY PREPARATION.....	5
6.2 BATTERY CHARGER/BATTERY CONNECTION.....	5
6.3 MANUAL CHARGING AND AUTOMATIC CHARGING.....	5
6.3.1 MANUAL CHARGE.....	5
6.4 SIMULTANEOUS CHARGING OF SEVERAL BATTERIES ...	5
6.5 END OF CHARGE.....	5
7. OPERATION DURING STARTIN G.....	5
7.1 BATTERY CHARGER/BATTERY CONNECTION.....	5
7.2 STARTING UP WITH START.....	5
7.3 END OF STARTING.....	5
8. BATTERY CHARGER PROTECTION	5
9. USEFUL ADVICE	6



DANGER OF EXPLOSION



GENERAL HAZARD



DANGER OF CORROSIVE SUBSTANCES



Symbol indicating separation of electrical and electronic appliances for refuse collection. The user is not allowed to dispose of these appliances as solid, mixed urban refuse, and must do it through authorised refuse collection centres.

1. GENERAL SAFETY RULES FOR THE USE



- During the charge the battery produces explosive gases, avoid the formation of flames and sparkes. **DO NOT SMOKE.**
- Position the batteries to be charged in a well-ventilated place.



- **Inexperience and untrained people should be properly instructed before using the appliance.**
- **People (children included) whose physical, sensory or mental capacities would prevent them from using the appliance correctly must be supervised by a person who is responsible for their safety while the appliance is in use.**
- **Children must be supervised to ensure that they do not play with the appliance.**

- Use the battery charger only indoors and make sure that you start it in dry places. DO NOT SET IN THE RAIN OR SNOW.
- Disconnect the mains cable before connecting to or disconnecting the charging cables from the battery.
- Do not connect or disconnect the clamps to or from the battery with the battery charger operating.
- Never use the battery charger inside the car or in the bonnet.
- Substitute the mains cable only with an original one.
- Do not use the battery charger to charge batteries which are not rechargeable.

- Make sure the available power supply voltage corresponds to that on the battery charger rating plate.
- To prevent damaging the vehicle electronics, scrupulously respect the warnings given by the producer of the vehicle or the batteries used.
- This battery charger has components such as switches and relays which can cause arcs or sparks. Therefore when using it in a garage or in a similar place set the battery charger in a suitable case.
- Repair or maintenance of the inside of the battery charger can be executed only by skilled technicians.
- **WARNING: ALWAYS DISCONNECT THE POWER SUPPLY CABLE FROM THE MAINS BEFORE CARRYING OUT ANY SIMPLE MAINTENANCE OPERATION ON THE BATTERY CHARGER.**
- The battery charger is protected from indirect contact by an earth wire as indicated for class I equipment. Make sure the power outlet is protected by an earth connection.

capacitance suitable for the value of the fuse shown in the plate; for models supplied with cable and plug and with a "P.MAX START" power higher than 9kW, when used for starting, we advise replacing the plug with one having a capacitance suitable for the fuse shown in the plate.

2. GENERAL DESCRIPTION

2.1 TRADITION

Manual battery chargers (the operator must intervene to stop the charge process) indicated for charging free electrolyte lead acid batteries (WET) used in engine-driven vehicles (petrol and diesel), motorcycles, boats, etc. 6V, 12V and 24V batteries can be recharged according to the available output voltage. Some models have the START mode to start engine-driven vehicles.

3. BOOST FUNCTIONS

These functions speed up charging and help vehicle starting thanks to fast battery pre-charge (the charging time depends on the battery capacity and discharge level).

4. AMMETER READING

The ammeter allows reading the current supplied by the battery charger to the battery (a completely flat battery initially requires maximum current which lowers over time). During the charging phase the ammeter indicator moves from right to left, indicating a decrease in the current required by the battery until very low levels (near to zero) are reached (fully charged battery), at a speed and with an accuracy that depend on the capacity, battery state and ammeter reading precision. Please remember that the exact charge status of the battery can only be determined by using a densimeter which allows measurement of the specific gravity of the electrolyte. With manual battery chargers, the ammeter must be monitored to determine when the battery has finished charging. Once the battery is charged it must be disconnected to prevent overheating or damage.

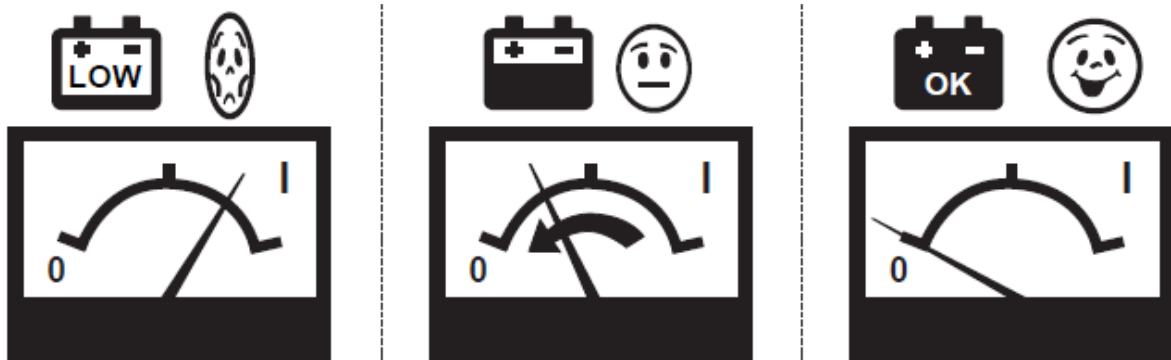

5. INSTALLATION

5.1 ASSEMBLY

Unpack the battery charger and assemble the separate parts contained in the package. Models on wheels are to be set in a vertical position.

5.2 POSITIONING THE BATTERY CHARGER

During operation, position the battery charger on a stable surface and make sure that there is no obstruction to air passage through the openings provided to ensure sufficient ventilation.

5.3 CONNECTION TO THE MAIN SUPPLY

- The battery charger should be connected only and exclusively to a power source with the neutral lead connected to earth. Check that the mains voltage is the same as the voltage of the equipment.

- Check that the power supply is protected by systems such as fuses or automatic switches, sufficient to support the maximum absorption of the equipment.
- The connection to the main supply has to be made using a suitable cable.
- If you put an extension to the primary cable, the section should be adequate and, in any case, never less than that of the cable supplied.
- You always have to earth the equipment with the yellow/green wire contained in the main cable, indicated by the label (W), while the other two wires should be connected to the phase and the neutral cable.

6. OPERATION DURING CHARGING

Before charging check that the capacity of the battery (Ah) which is to be charged, is not inferior to that reported on the data table of the battery charger (C min). Follow the instructions, taking great care to respect the order given below.

6.1 BATTERY PREPARATION

When recharging a WET-type battery, proceed as follows:

- Remove the caps of the battery charger (if foreseen) so as to let the gas produced go out. Check that the level of the electrolyte covers the plates of the battery. If these were not covered add distilled water and cover them up to 5-10 mm.



WARNING: USE THE MAXIMUM CAUTION DURING THIS OPERATION AS THE ELECTROLYTE IS A HIGHLY CORROSIVE ACID .

6.2 BATTERY CHARGER/BATTERY CONNECTION

- Make sure the power cable is disconnected from the mains.
- With models having more than one charge voltage, turn the deviator or the switch to the selected charge voltage. If there is no deviator or switch, suitably connect the red crocodile clip (+ symbol) to the specific battery charger terminal in correspondence with the selected charge voltage.
- Connect the red charge clamp to the positive terminal of the battery (+ symbol). If the symbols are indistinguishable remember that the positive terminal is the one not connected to the vehicle chassis.
- Connect the black charge clamp to the vehicle chassis, at a safe distance from the battery and the fuel pipe.

NOTE: if the battery is not installed in the vehicle, connect the clamp directly to the negative terminal of the battery (- symbol).

6.3 MANUAL CHARGING AND AUTOMATIC CHARGING

NOTE: the Ah values, if given beside the pushbuttons, are purely indicative (because the charging process depends on how flat the battery is) and they

suggest the position for charging an initially flat battery with capacity within the indicated range, in under 15 hours. It is not advisable to go below the minimum values that are indicated.

6.3.1 MANUAL CHARGE 

Recommended method for free electrolyte lead acid batteries (WET).

- Carefully follow the instructions given in paragraphs 6.1 and 6.2.
- Move the deviator (if present) to the BATTERY symbol.
- Turn the charge adjustment deviator/deviators or switch (if present) the normal charge position (BATTERY symbol) or fast charge position (BOOST) as required (with some models the switch also acts as a power switch).
- If the battery charger has a TIMER a maximum pre-set charge time can be set.
- Power the battery charger by inserting the power supply cable into the power outlet and turning the switch (if present) to ON.
- Monitor the ammeter as described in paragraph 4.

NOTE: Once the WET battery is charged, you may note the liquid inside starting to “boil”. It is advisable to stop charging when this phenomenon appears so as to prevent damage to the battery.

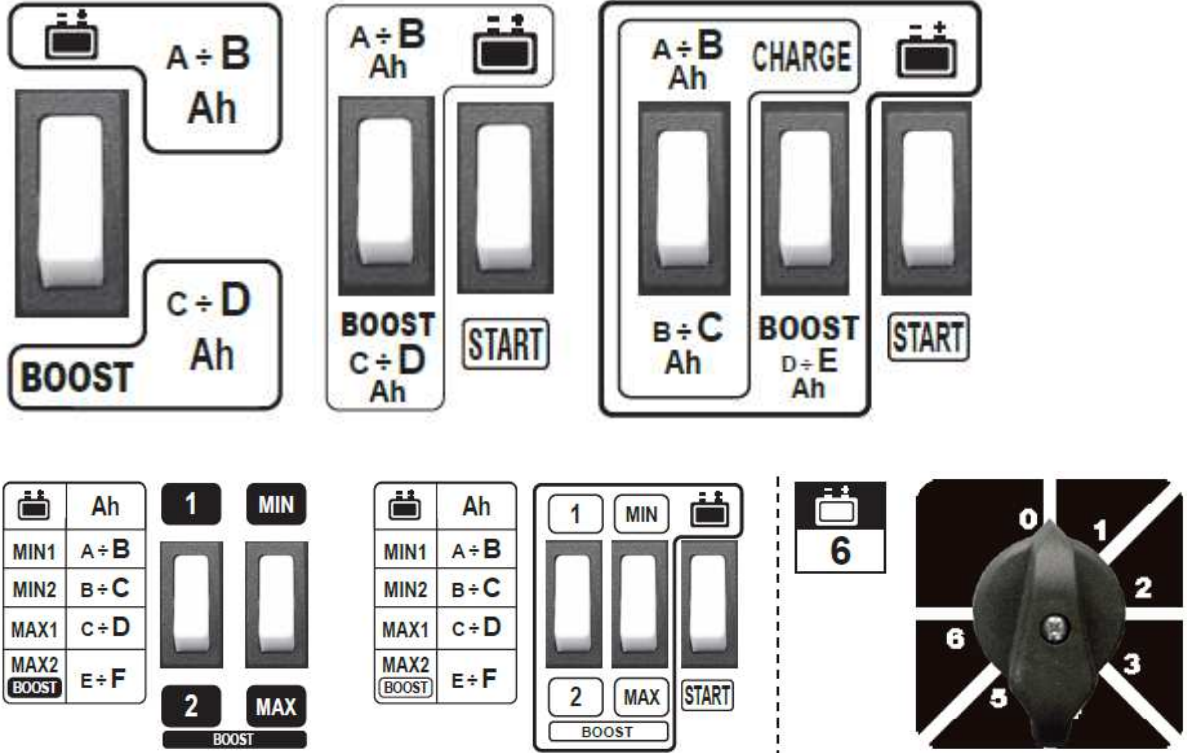

6.3 SIMULTANEOUS CHARGING OF SEVERAL BATTERIES

WARNING; do not simultaneously charge different types of batteries or batteries with different capacities or levels of discharge. If you have to charge more than one battery at the same time you can connect them “in series” or “in parallel”.

For “parallel” connection batteries must have the same nominal voltage (Volt), which corresponds to the battery charger output voltage, and the total of Ah must be within the charge range of the battery charger. For “serial” connection batteries must have the same capacity (Ah) and the sum of the nominal voltages of all the batteries must correspond to the battery charger output voltage.

SERIES CONNECTION

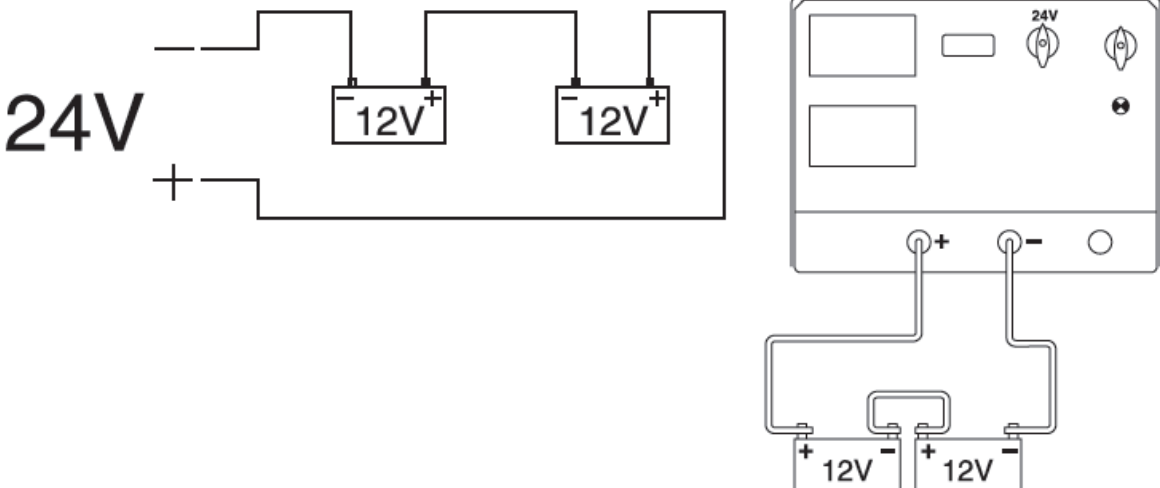

PARALLEL CONNECTION

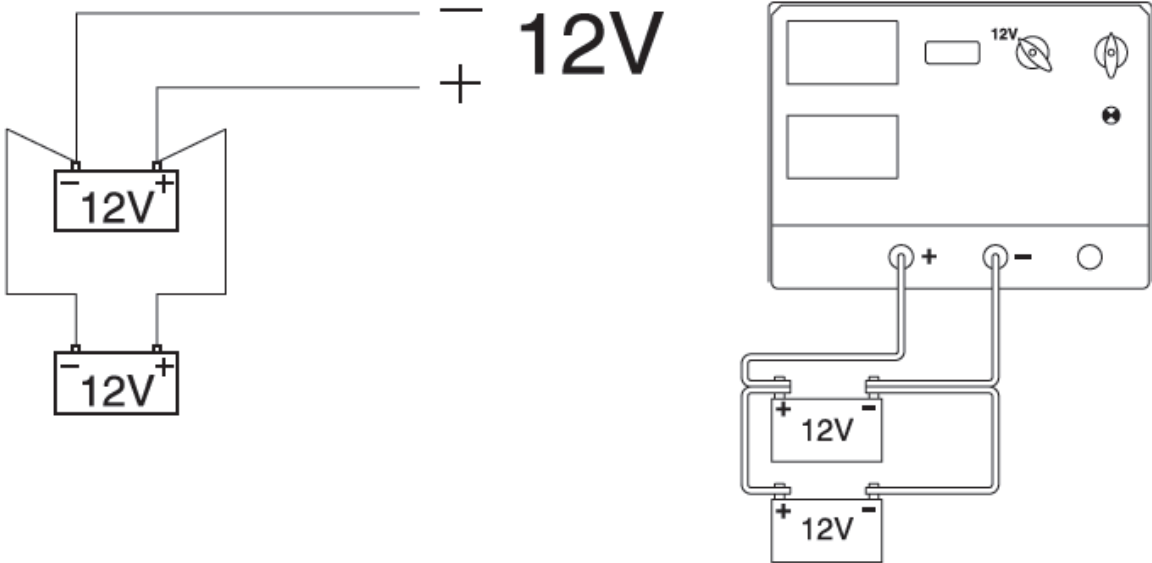

6.4 END OF CHARGE

- Remove the power supply from the battery charger by turning the switch to OFF (if present) and/or removing the power supply cable from the mains outlet.
- Disconnect the black charge clamp from the chassis of the vehicle or from the negative terminal of the battery (- symbol).
- Disconnect the red charge clamp from the positive terminal of the battery (+ symbol).
- Store the battery charger in a dry place.
- Close up the battery cells with the appropriate plugs (if present).

7. OPERATION DURING STARTING

WARNING: Before proceeding with starting follow the vehicle manufacturer's instructions carefully!

- Make sure the power line is protected by fuses or automatic circuit-breakers with sizes as indicated on the rating plate by the () symbol
- To make starting easier, quickly charge for 10-15 minutes at the BOOST position (see paragraph 6.3.1).
- In order to prevent overheating in the battery charger, ALWAYS carry out the starting operation according to the duty cycle (work/ pause) as indicated on the appliance (e.g. START 3s ON 120s OFF-5 CYCLES). Do not insist if the engine does not start: this could cause serious damage to the battery or even to the electrical equipment in the vehicle. If the engine does not start, wait a few minutes and then repeat the rapid charge operation.

7.1 BATTERY CHARGER/BATTERY CONNECTION

- With the power cable disconnected from the mains, if necessary, turn the deviator to 12V or 24V or suitably connect the red crocodile clip to the specific battery charger terminal, according to the nominal voltage of the battery of the vehicle to be started.
- Make sure the battery is connected properly to the respective (+ and -) terminals, and that it is in good condition (not sulphated or dud). Never ever start vehicles with the batteries disconnected from their respective terminals; the presence of the battery is essential for the elimination of possible overvoltage.

7.2 STARTING UP WITH START

- With the battery charger at OFF, plug in the power cable.
- Turn the switch, if present, to ON.
- Turn the switch to START and turn the ignition key to start up the engine.

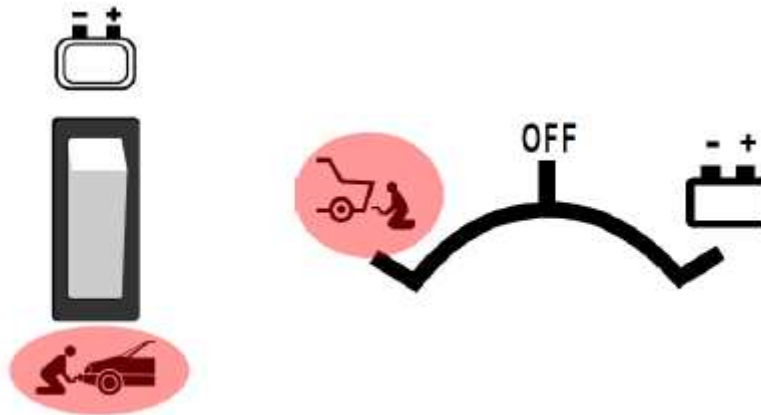

7.4 END OF STARTING

- Disconnect the power to the battery charger by turning the switch (if present) to OFF and remove the power cable from the mains.
- Disconnect the black crocodile clip from the negative battery terminal (- symbol) and the red crocodile clip from the positive battery terminal (+ symbol).
- Store the battery charger in a dry place.

8. BATTERY CHARGER PROTECTION

The battery charger protects itself from:

- Overcharge (too much current supplied to the battery).
- Short-circuit (loading clips placed in contact with each other).
- Polarity inversion on the battery clamps.

For appliances fitted with fuses, if the fuses have to be replaced always use the same kind of fuse with the same rated size. **WARNING:** If the replacement fuse has a different size from that shown on the rating plate it could cause damage to people or property. For the same reason, never ever replace the fuse with a bridge in copper or other material. The power supply cable should always be **DISCONNECTED** from the mains supply while the fuse is being changed. When replacing the ribbon fuse, if present, carefully fasten the nuts.

9. USEFUL ADVICE

- If the positive and negative terminals are incrustated with oxide, clean them to ensure good contacts with the clamps.
- Never ever allow the two clamps to come into contact when the battery charger is connected to the mains. In this case the fuse will blow.
- If the battery, to which this battery charger is to be connected, is permanently installed in the vehicle, also consult the vehicle manufacturer's user's and maintenance handbook under the "ELECTRICAL SYSTEM" or "MAINTENANCE" section.